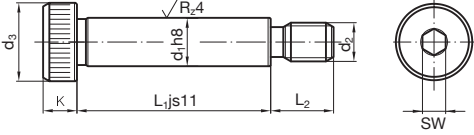

F
Zubehör

PS.01

Schulter-Paßschrauben

PS.01		Schulter-Paßschrauben						
		PS.01						
		d1	6	8	10	12	16	20
		d2	M5x0,8	M6x1	M8x1,25	M10x1,5	M12x1,75	M16x2
		d3	10	13	16	18	24	30
		l2	9,5	11	13	16	18	22
		K	4,5	5,5	7	8	11	14
		SW	3	4	5	6	8	10
		L1	16	16	16	-	-	-
			20	20	20	20	-	-
			25	25	25	25	-	-
			30	30	30	30	30	-
			40	40	40	40	40	40
			50	50	50	50	50	50
			-	60	60	60	60	60
			-	-	80	80	80	80
			-	-	-	100	100	100
	-	-	-	-	120	120		

Bestellbeispiel

Typ	PS.
Modell	01.
d1	020.
L1	100
Bestell.-Nr.	PS. 01.020. 100

DE.01

Distanzeinheiten

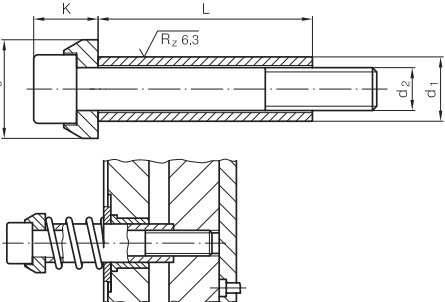
DE.01		Distanzeinheiten					
		DE.01					
		d1	10	12,5	15	17,5	23
		d2	M6	M8	M10	M12	M16
		d3	15	19	23	27	34
		K	10	13	15	18	24
		L	20	-	-	-	-
			30	30	30	-	-
			40	40	40	40	-
			50	50	50	50	50
			60	60	60	60	60
			-	70	70	70	70
			-	80	80	80	80
			-	-	100	100	100
			-	-	-	120	120

Bestellbeispiel

Typ	DE.
Modell	01.
d1	010.
L	050
Bestell.-Nr.	DE. 01.010. 050

ZS.01 Zylinderstifte

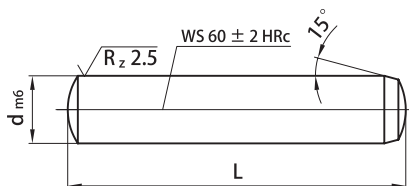
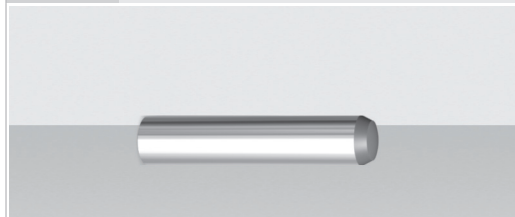

Werkstoff: WS

Bestellbeispiel

Typ	ZS.
Modell	01.
d	005.
L	060
Bestell.-Nr.	ZS. 01.005.060

ZS.01 Zylinderstifte

d	1,5	2	2,5	3	4	5	6	8	10	12	14	16	20
L	6												
	8												
	10	10	10	10	10	10	-	-	-	-	-	-	-
	12	12	12	12	12	12	12	-	-	-	-	-	-
	16	16	16	16	16	16	16	-	-	-	-	-	-
	-	-	-	-	-	-	18	-	-	-	-	-	-
	-	20	20	20	20	20	20	20	-	-	-	-	-
	-	-	24	24	24	24	24	24	24	-	-	-	-
	-	-	-	32	32	32	32	32	32	32	-	-	-
	-	-	-	-	40	40	40	40	40	40	40	-	-
	-	-	-	-	50	50	50	50	50	50	50	50	-
	-	-	-	-	-	60	60	60	60	60	60	60	60
	-	-	-	-	-	-	70	70	70	70	-	-	-
	-	-	-	-	-	-	-	80	80	80	80	80	80
	-	-	-	-	-	-	-	-	100	100	100	100	100
	-	-	-	-	-	-	-	-	-	120	120	120	120
	-	-	-	-	-	-	-	-	-	-	-	-	140

ZS.02 Zylinderstifte mit Innengewinde

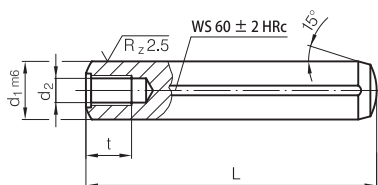

Werkstoff: WS

Bestellbeispiel

Typ	ZS.
Modell	02.
d1	010.
L	050
Bestell.-Nr.	ZS. 02.010.050

ZS.02 Zylinderstifte mit Innengewinde

d1	6	8	10	12	14	16	20
d2	M4	M5	M6	M6	M8	M8	M10
t	6	8	10	10	12	12	16
L	20	20	-	-	-	-	-
	24	24	24	-	-	-	-
	32	32	32	32	-	-	-
	40	40	40	40	40	40	-
	50	50	50	50	50	50	50
	60	60	60	60	60	60	60
	-	80	80	80	80	80	80
	-	-	100	100	100	100	100
	-	-	-	120	120	120	120

GS.01

Gewindestifte

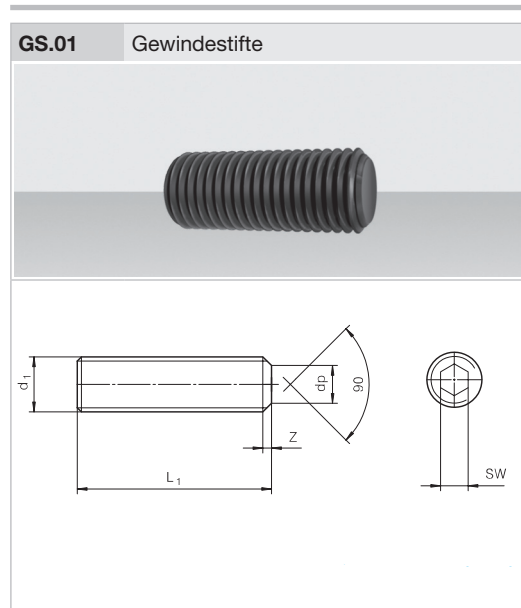

Bestellbeispiel

Typ	GS.
Modell	01.
d1	M5.
L1	020
Bestell.-Nr.	GS.01.M5.020

GS.01 Gewindestifte

d1	M4	M5	M6	M8	M10	M12	M16
SW	2	2,5	3	4	5	6	8
z	0,75	0,75	1	1,25	1,5	1,75	2
dp	2	3,5	4	5,5	7	8,5	12
L1	6	6	-	-	-	-	-
	8	8	8	8	-	-	-
	10	10	10	10	10	-	-
	12	12	12	12	12	12	-
	-	16	16	16	16	16	-
	-	20	20	20	20	20	20
	-	-	25	25	25	25	-
	-	-	30	30	30	30	30
	-	-	-	35	35	35	-
	-	-	-	40	40	40	40
	-	-	-	-	45	45	-
	-	-	-	-	50	50	-
	-	-	-	-	-	60	-

GS.02

Gewindestifte mit Zapfen

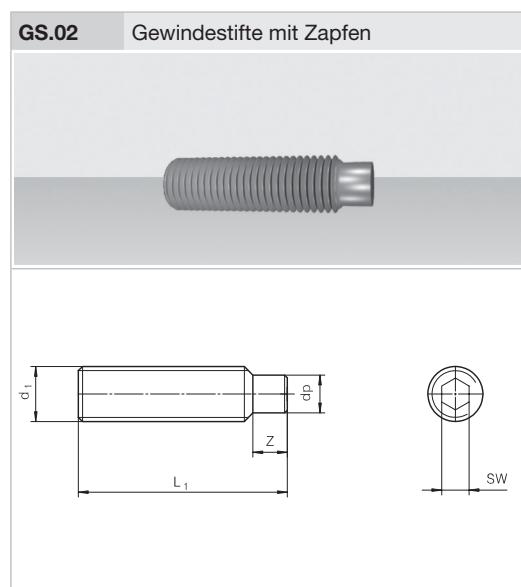

Bestellbeispiel

Typ	GS.
Modell	02.
d	M6.
L1	020
Bestell.-Nr.	GS.02.M6.020

GS.02 Gewindestifte mit Zapfen

d1	M4	M6	M8	M10	M12	M16
Z	2	3	4	5	6	8
dp	2,5	4	5,5	7	8,5	12
SW	2	3	4	5	6	8
L1	10	-	-	-	-	-
	-	12	-	-	-	-
	-	16	16	-	-	-
	-	20	20	20	-	-
	-	25	25	-	-	-
	-	-	30	30	30	-
	-	-	-	40	40	40
	-	-	-	50	50	50
	-	-	-	-	-	60

DS.01

Federnde Druckstücke mit Kugel

DS.01 Federnde Druckstücke mit Kugel

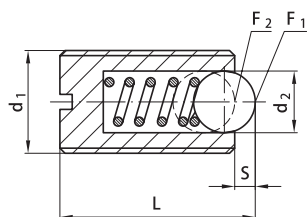

Bestellbeispiel

Typ	DS.
Modell	01.
d1	M5
Bestell.-Nr.	DS.01.M5

DS.01 Federnde Druckstücke mit Kugel

d1	M4	M5	M6	M8	M10	M12	M16
L	9	12	14	16	19	22	24
S	0,8	0,9	1	1,5	2	2,5	3,5
d2	2,5	3	3,5	5	6	8	10
F1 (N)	6	7	9	20	25	35	65
F2 (N)	12	13	15	35	45	60	110

FB.01

Streifenführungsbolzen

FB.01 Streifenführungsbolzen

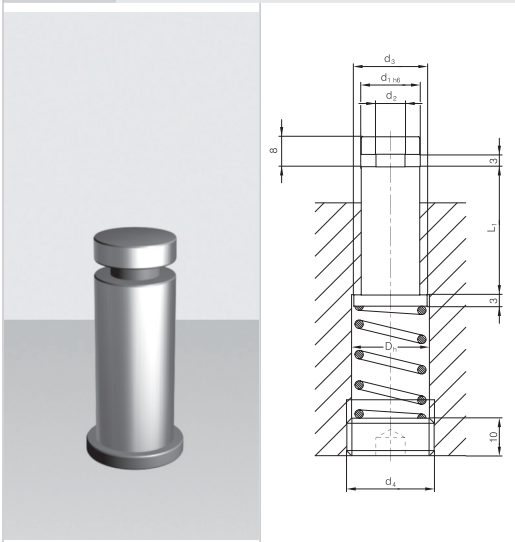

Bestellbeispiel

Typ	FB.
Modell	01.
d1	010.
L1	040
Bestell.-Nr.	FB.01.010.040

FB.01 Streifenführungsbolzen

d1	8	10	13	16
d2	5	6	7	8
d3	10	12	16	20
d4	M12 x 1,5	M14 x 1,5	M15 x 1,5	M22 x 1,5
Dh	10,5	12,5	16,5	20,5
L1	20	-	-	-
	25	25	25	
	32	32	32	32
	40	40	40	40
	-	50	50	50

Tragelemente

TE.01 Ringschrauben DIN 580

TE.01 Ringschrauben

d1	M8	M10	M12	M16	M20	M24	M30
d2	36	45	54	63	76	90	106
d3	20	25	30	35	42	50	56
d4	20	25	30	35	48	56	65
h1	36	44,5	53	63,5	76	90	107
h2	15	18	22	26	30	35	45
K	8	10	12	14	17	20	24
Z1max	140	230	340	700	1200	1800	3600
Z2max	95	170	240	500	830	1270	2600
	-	-	-	-	-	120	120

TE.02 Tragschrauben VDI 3366

TE.02 Tragschrauben

d1	M16	M20	M24	M30	M36
d	16	20	25	32	40
Z1(N)	4000	5000	6300	10000	16000
SW	27	32	36	41	50
L2	6	8	10	12	12
L3	22	25	32	40	50
L4	6	7	8	10	10
L5	50	60	75	94	112

TE.03 Tragzapfen VDI 3366

TE.03 Tragzapfen

d	16	20	25	32	40	50
a	20	25	35	40	50	60
Z1(N)	3200	6300	12500	20000	32000	50000
M	M8	M10	M12	M16	M20	M24
d2	9	11	14	18	22	26
L2	6	8	8	10	10	12
L3	20	25	30	32	40	45
L4	80	90	100	120	140	160
L5	10	10	12	16	18	22
L6	34	37	38	46	54	59

Bestellbeispiel

Typ	TE.
Modell	02.
d1	M16
Bestell.-Nr.	TE. 02.M16